



Construction type

Ventilation Ductwork



## Fire Duct Systems (previously Conlit® Ductwork System)

Single layer fire protection for rectangular, circular and oval ducts

As part of the comprehensive FirePro range of fire protection products, Fire Duct systems provide fire protection and thermal and acoustic insulation for circular and rectangular steel ductwork.

The simplicity and flexibility of fixing options ensure rapid and reliable installation to both vertical and horizontal duct systems.

Three products are available in the Fire Duct range:-

**Fire Duct Slab** – for rectangular ducts

**Fire Duct Section** – for circular ducts between 60mm and 356mm diameter.

**Fire Duct PSM** – for circular ducts greater than 406mm diameter

All three Fire Duct products are supplied faced on one side with reinforced aluminium foil.

### Advantages

- Specified with confidence
- Installed quickly, simply and reliably
- Fully certified to BS 476-24 (duct types A and B)
- ½, 1, 1½ and 2 hour fire protection for stability, integrity and insulation
- Choice of fixing options
- Single layer, enabling verification of system installation
- Space efficient, non-brittle, strong and safe
- Multi-role insulation: fire protection, acoustic and thermal



## Contents

System options .....	2	Ancillaries and fixings .....	5
Standards and regulations .....	2	Wall penetrations .....	6
Circular and oval ducts .....	3	Two and three-sided applications and elbows .....	6
Product properties .....	4	Access hatches .....	6
Fire protection thicknesses .....	4	Criteria for ductwork .....	7
Hangers, bearers and flanges .....	4	Typical specification clauses .....	8



Rockwool supports FIRAS  
 accredited installers

# Fire Duct Systems – overview and standards

## The requirements for ductwork fire protection

Three performance criteria; stability, integrity and insulation, are required in equal measure for all ducts which pass through fire-rated walls or floors.

BS 5588 – 9, Clause 6.2.5.3 requires that, for fire-resisting ductwork:

‘The fire resistance of the ductwork, when tested from either side, should not be less than the fire resistance required for the elements of construction in the area through which it passes’

BS 476 – 24, Clause 9.1 states that:

*‘The fire resistance of test specimens shall be the duration in minutes, of heating in accordance with 5.1.1 until failure occurs according to one or more of the performance criteria, ie, stability, insulation, integrity, or until the test is terminated, whichever is the shortest time’*

## Fire Duct System test data

The Fire Duct products have been tested and assessed by BRE LPC in accordance with BS 476 – 24, ‘Fire tests on building materials and structures – Methods for determination of the fire resistance of ventilation ducts’.

Fire Duct products can be used to provide fire protection to horizontal, vertical, rectangular, circular, ventilation and smoke extract steel ductwork fully in accordance with BS 476 – 24, ducts ‘Type A’ and ‘Type B’, ‘Fire outside duct’ and ‘Fire inside duct’.

The ½, 1, 1½, and 2 hour periods of fire resistance stated in this manual are for stability, integrity and insulation in equal measure. For example, the 60 minutes duct constructions shown are certified for 60 mins stability, 60 mins integrity and 60 mins insulation .

‘Kitchen extract’ ducts

These are subject to separate BS 476–24 requirements, and are additionally covered for ½ and 1 hour protection periods.

## System options – rectangular ducts

### Welded pin fixing method

Attachment by welded pins allows extremely rapid installation with slab joints simply butted together.

Welded pins are generally spaced at 350mm maximum centres along the length of the duct and at at 500mm maximum centres across the width and depth of the duct. Pins are required on all four sides of vertical ducts, but may be omitted from the top face of horizontal ducts (see page 5).

Longitudinal corner joints fixed with pigtail screws at 250mm maximum centres (screw length to be  $2 \times$  slab thickness). Side wall slabs must overlap top and bottom slabs (as shown). Cross joints bonded with FirePro Glue.

### Alternative joint methods

Instead of pigtail screws, longitudinal joints can be fixed with FirePro Glue and nails, at 500mm max. centres.

Instead of glue, cross joints can be protected with centrally positioned, 100mm wide Fire Duct strips fixed along both edges with pigtail screws at 250mm max. centres.

### Mitre-joint fixing methods

The use of mitre-joints at slab corners allows installation in situations where welding may not be practicable.

Nails are generally spaced at 500mm maximum centres (see page 5). See ‘Fire resistance’ table on page 4 for limitations on duct sizes.

*Mitre-joint method*

All joints bonded with FirePro Glue. Longitudinal corner joints secured with nails while FirePro Glue cures.

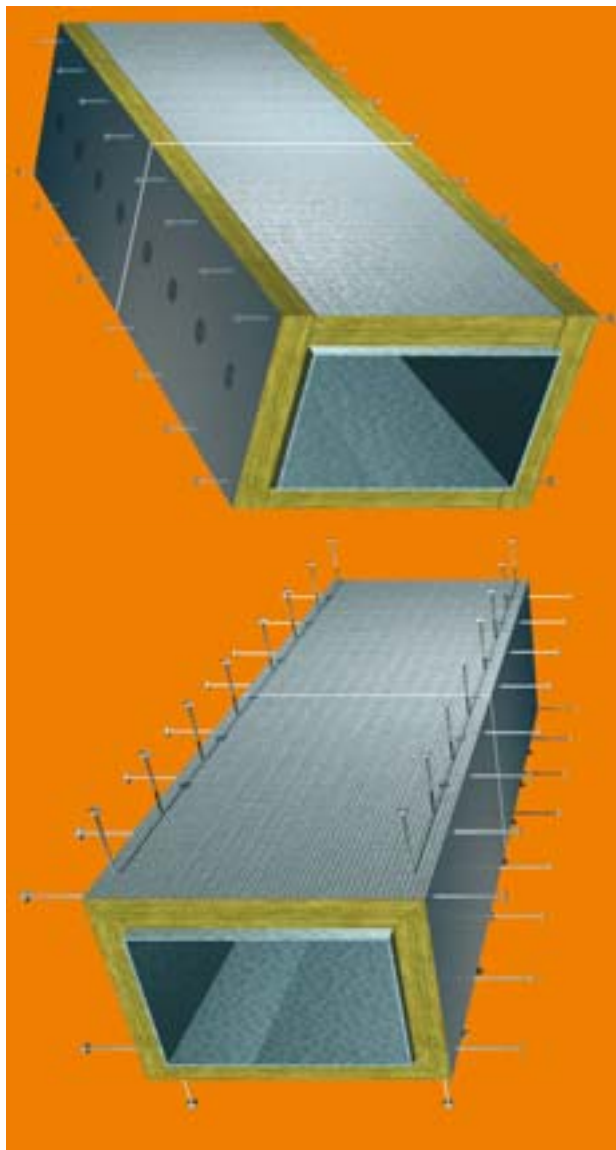

# System options – circular ducts

## Fire Duct Section

Circular steel ducts of between 60mm and 356mm diameter may be protected using Fire Duct Section.

Fire Duct Section must be glued with FirePro Glue at the joints and in the grooves. Steel bands or wires must be fitted circumferentially to the system at 300mm nominal centres to hold all joints and grooves tightly closed while the glue cures.

Where required, cover strips and bearer protection pieces are to be cut from Fire Duct Section (or Fire Duct PSM) of the appropriate diameter. The foil covering is to be removed from the area of Fire Duct Section immediately beneath the cover strips prior to gluing into position and securing with steel nails or pins.

Self adhesive aluminium foil tape may be used to seal the joints where a vapour barrier is required.

The hanger system is as described on page 4, with the angle bearer formed into a circular shape to suit the diameter of the duct or the Fire Duct Section (depending on whether the hanger is located inside or outside the protection).

Fire Duct Section is used to protect the drop rods as described on page 4. General installation principles are as otherwise described in this manual for Fire Duct Slab.

### Fire Duct PSM

Circular steel ducts of 406mm and greater diameter may also be protected using Fire Duct PSM.

Fire Duct PSM must be glued at the joints and in the grooves with FirePro Glue. Steel bands or wires must be fitted circumferentially to the system at 300mm nominal centres to hold all joints and grooves tightly closed while the glue cures.

General duct, hanger and installation details are as described for Fire Duct Section.

Figure 1 Fire Duct Section applied to circular duct

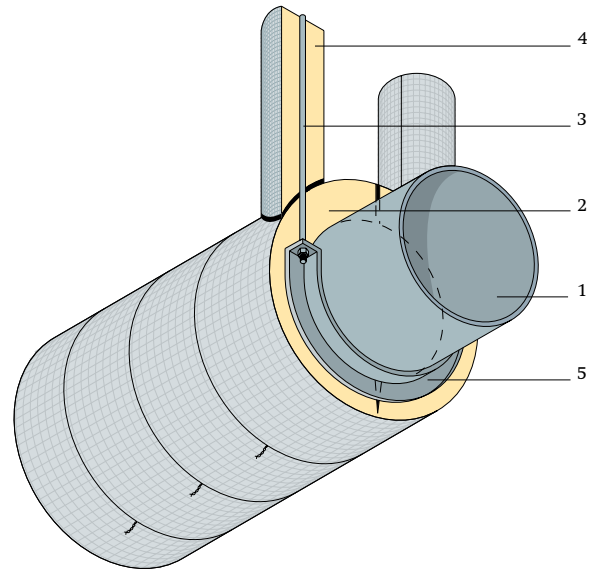
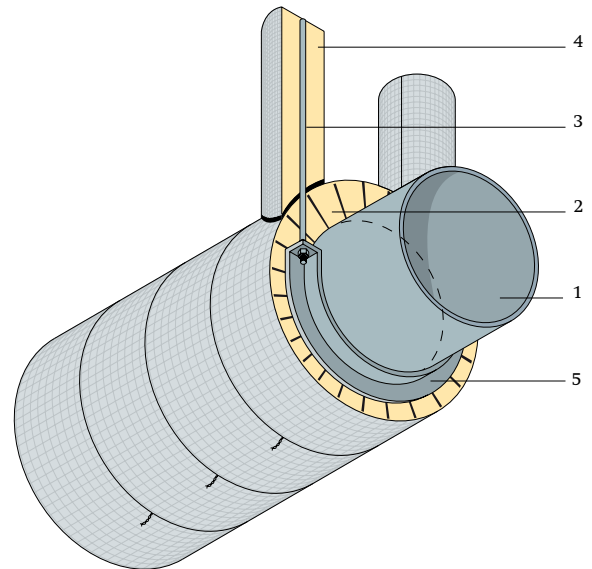

Figure 2 Fire Duct PSM applied to circular duct



### Notes to Figures 1 and 2

- 1 Circular steel duct to DW/144
- 2 Fire Duct Section/Fire Duct PSM
- 3 M10 steel drop rods at 1500mm maximum centres
- 4 Fire Duct Slab/Section – protection to hanger system
- 5 30 × 30 × 3mm minimum steel angle bearer

# Description, performance and properties

## Fire resistance

Performance summary – Fire Duct Slab, Section and PSM

Fire resistance (hours)	Duct type	Required Fire Duct thickness (mm)	Joint options (see Fig. 3 below)	Hanger protection		Max. duct size for mitre-joint, glued system (mm)
				Fire Duct Slab (mm)	Hanger Section (mm)	
½	HVAC & Smoke extract	40	B C	40	17 × 30	1500 × 1500
	Kitchen extract	40	B C	40	17 × 30	1500 × 1500
1	HVAC & Smoke extract	40	B C	40	17 × 40	1000 × 1000
	Kitchen extract	90	A B C	40	17 × 40	1500 × 1500
1½	HVAC & Smoke extract	90	A B C	90	17 × 50	1200 × 1200
2	HVAC & Smoke extract	90	A B C	90	17 × 60	1000 × 1000

## Product descriptions

### Fire Duct Slab

- Size: 1200 × 2000mm
- Thicknesses: 40 & 90mm
- Facing: reinforced aluminium foil
- Surface spread of flame: Class 1 to BS 476-7
- Non-combustibility: Class A1 to BSEN 13501-1 (wall & ceiling linings)
- Thermal conductivity: 0.035 W/mK at 10°C

### Fire Duct Section

Diameters: 60 to 356mm  
 Thicknesses: 40 and 90mm\*  
 Facing: reinforced aluminium foil

### Fire Duct PSM

Fire Duct PSM is made of Fire Duct Slab with factory machined grooves to suit specific duct diameters.

Diameters: 406mm and above  
 Thicknesses: 40 and 90mm\*  
 Facing: reinforced aluminium foil

\* Some thicknesses of Fire Duct Section and Fire Duct PSM are not available for certain duct diameters.

### Hanger sections

Diameter: 17mm  
 Thicknesses: 30, 40, 50 & 60mm  
 Facing: reinforced aluminium foil

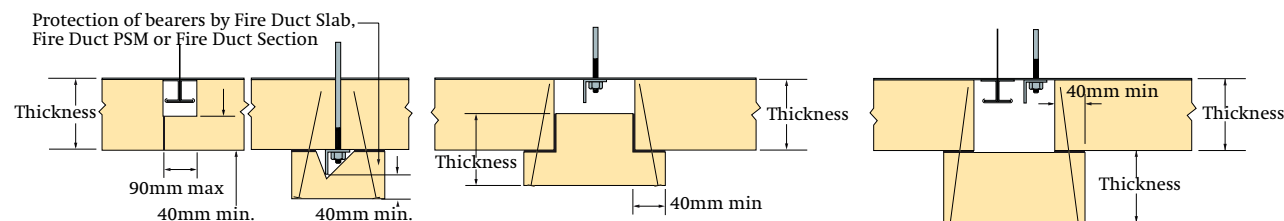

Figure 3 Joint Option A – Rebated protection      Joint Option B – Protection using ‘T’ section      Joint Option C – Protection using block cover strip

# Hangers, bearers and flanges

## Installation guidance

Fire Duct products are approved to provide fire protection to steel ductwork, wholly constructed using steel fixings in accordance with current HVCA specification DW/144 and superseded specification DW/142.

Where there are constructional options within DW/144 and DW/142, these are expanded upon below. These details are primarily concerned with duct joint types and the suspension method.

DW/142 flanged cross joint types J3, J4, J5 and J6 are acceptable for use with the Fire Duct System, without modification.

### Dimensions

Item	Duct size (mm)		
	Up to 1500 × 1500	Up to 2000 × 2000	Up to 3000 × 3000*
Maximum hanger centres (mm)	1500	1500	1500
Minimum drop rod size	M10	M10	M12
Minimum angle bearer (mm)	30 × 30 × 3	50 × 50 × 5	50 × 50 × 6

\* DW/144 and DW/142 do not specifically cover ducts larger than 3 m wide. Please contact Rockwool for details.

Fire Duct Slab, Fire Duct Section or Fire Duct PSM may be installed either outside or inside the hanger system.

Bearers will require additional protection only when positioned outside the Fire Duct layer.

Drop rods will normally be protected with Fire Duct Section or with Fire Duct Slab blocks (see Figure 4).

Alternatively, the support steelwork may be sized so that separate protection is not required. Design of this ‘unprotected support’ method is independent of the Fire Duct System.

### Protection of hangers outside Fire Duct System

Hangers outside the Fire Duct System are protected by cutting a rebate into a block of Fire Duct Slab, Fire Duct PSM or Fire Duct Section.

The rebate should be no larger than necessary to accommodate the bearer. The block should be glued and pinned in position (see Figure 3, Option A) or secured using pigtail screws.

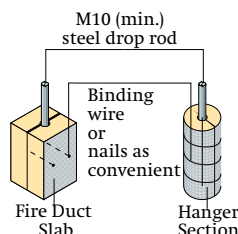

Figure 4 Isometric view of drop rod protection options

# Ancillaries

## Welded steel pins

Welded pins are generally spaced at 350mm maximum centres along the length of the duct and at 500mm maximum centres across the width and depth of the duct. Pins are required on all four sides of vertical ducts, but may be omitted from the top face of horizontal ducts (see Figures 5 and 6).

Details of alternative mechanically fixed pins are available from Rockwool on request.

## FirePro Glue

FirePro Glue has a pH value of 11. It is provided in 17 kg drums and should always be stirred before use.

Where required, 1–1.5mm of glue should be applied to each Fire Duct joint. The glue is generally applied by spatula or trowel.

Where present, any foil facing must be removed from surfaces prior to the application of FirePro Glue.

## Nails (for use only with mitre-joint 'glued' systems)

The nail length is to be  $2 \times$  board thickness (see Figure 7 for positions).

## Pigtail screws

Pigtail screws are to be used at all corner joints where FirePro Glue is not used, and to secure cross joint cover strips.

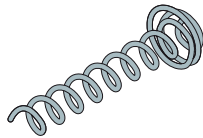

Pigtail screws are to be positioned at 250mm maximum centres, and the screw length is to be  $2 \times$  slab thickness.

For horizontal ducts, pigtail screws must be inserted horizontally, as shown on pages 2 and 3.

## Optional edge protection

Light gauge metal angles may be glued in position to provide optional edge protection. The metal angles must be de-greased. Small pins may be required to hold the angle to the underside of the duct.

## Vapour barrier

Where a vapour barrier is required, all exposed Fire Duct edges and penetrations through the foil must be sealed using aluminium foil tape.

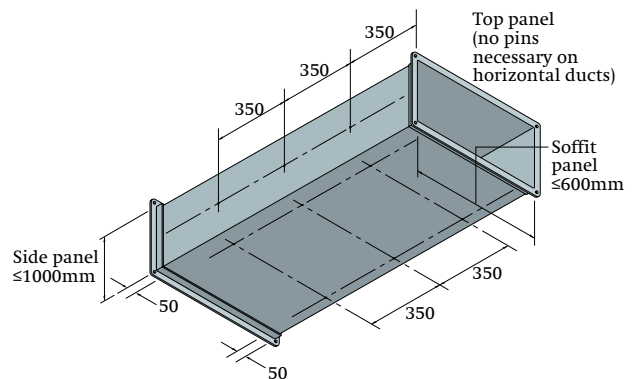

Figure 5 Steel pin arrangement where side panel does not exceed 1000mm and soffit panel does not exceed 600mm

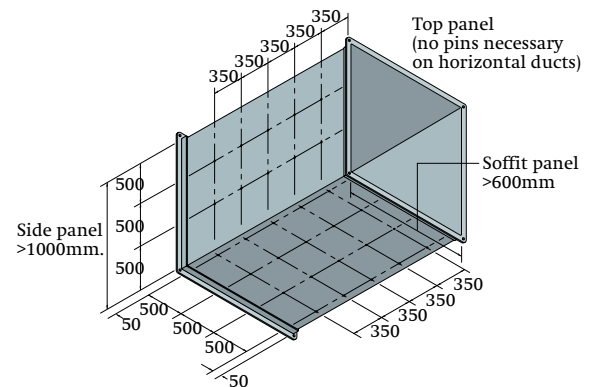

Figure 6 Steel pin arrangement where side panel is greater than 1000mm or soffit panel is greater than 600mm

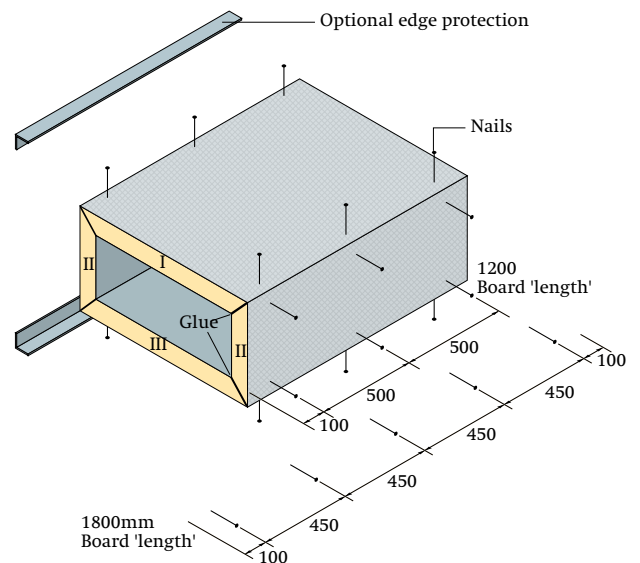

Figure 7 Rectangular ducts – 45° mitre joint system, showing installation sequence

# Wall penetrations, elbows, 2 and 3-sided applications and access hatches

## Wall and floor penetrations

Support to duct sides is required at all penetrations for stability purposes. This support can be provided by:

- a a  $30 \times 30 \times 2\text{mm}$  mild steel angle frame fixed to the duct at the penetration mid point. Steel rivets should be used at 300mm maximum centres (Figure 8),
- b locating the duct joint at the penetration mid point.

In all cases, low density Rockwool (typically RWA45) is packed tightly into the void between the Fire Duct product and the wall opening.

120mm wide blocks of Fire Duct are glued (or secured with pigtail screws) to the duct insulation and to the wall on both sides of the penetration.

All Fire Duct to wall joints are glued. Aluminium foil is located in Fire Duct joints at wall penetrations (as shown).

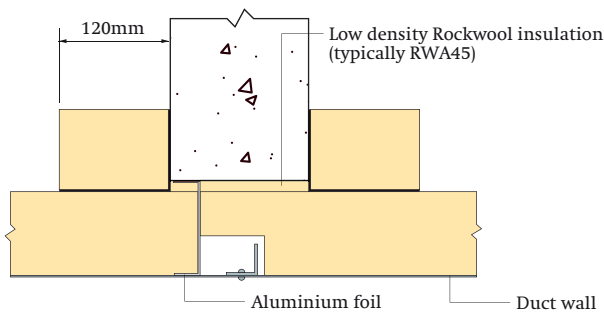

Figure 8 Steel angle frame support to duct at penetration mid point

## Proprietary penetration seals

Where proprietary penetration seals are used, compatibility with the separating element, duct construction and Fire Duct System must be demonstrated by independent test or assessment.

## Elbows (rectangular ducts)

Small elbows may simply be boxed or 'squared off'. Larger elbows may need to be protected by cutting fan shaped pieces, generally in accordance with the illustration (Figure 9).

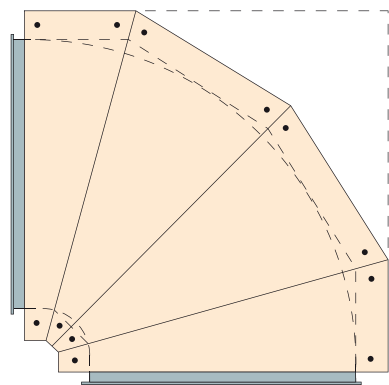

Figure 9 Typical elbow detail for rectangular ducts

## Two and three-sided applications (rectangular ducts)

The use of Fire Duct products incorporating welded pins is recommended for 2 and 3-sided applications.

The method illustrated (Figure 10) for three-sided applications, may also be used for two-sided applications where the duct is securely braced in the corner of a room.

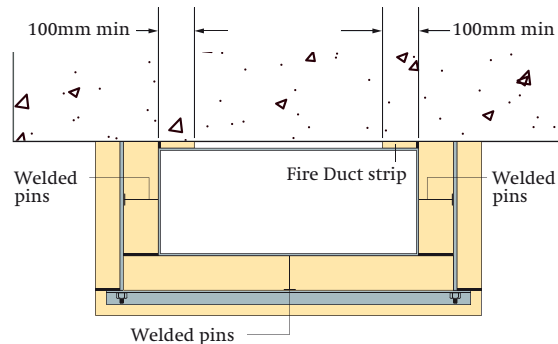

Figure 10 Three sided protection for rectangular ducts, using welded pin fixing method

## Access hatches (rectangular ducts)

Steel access hatches which are constructed and fitted in accordance with DW144 may be protected with Fire Duct Slab (figure 11).

The Fire Duct cover may be fitted in any face of the duct. However, if the sliding cover is not in the horizontal plane the guides must be positioned so as to prevent movement of the cover due to weight, vibration etc.

The sliding cover must be a tight fit in the guides. No part of the arrangement may be within 50mm of edges or joints within the main duct protection layer of Fire Duct Slab.

All Fire Duct Slab joints (excluding sliding joints) are to be glued and pinned as previously detailed.

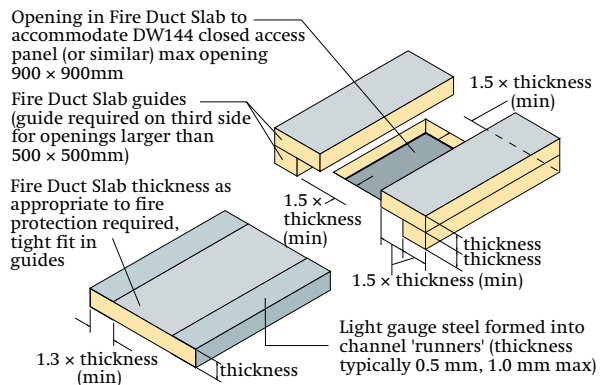

Figure 11 Removable cover panel for steel access hatch

## Access hatches (circular ducts)

Details of access hatches for circular ducts are available on request.

# Criteria for preparation of ductwork prior to insulation

Fire Duct products are certified to provide fire protection to ductwork conforming to Construction Details 1 to 12 in the table below and to the requirements of HVCA Specification DW/144. The table may be used as a check list for on-site verification of ductwork construction.

Project reference				
Job location				
	Construction detail	Requirement	Within specification?	Details of modification where needed
1	Duct sheeting	Rigid steel (zinc-coated, alu-zinc coated, black or stainless).		
2	Sheet thickness	0.8mm or greater. See DW/144 for ducts larger than 1500mm.		
3	Maximum duct size			
3a	Welded pin fixing methods	<p>Up to 1500mm × 1500mm: no additional system modifications.</p> <p>Up to 2000mm × 2000mm: increase angle bearer size to 50 × 50 × 5mm min.</p> <p>Up to 3000mm × 3000mm: increase angle bearer size to 50 × 50 × 6mm min.</p> <p>Increase drop rod diameter to M12 min.</p> <p>Up to 4000mm × 4000mm: 50 × 50 × 6mm min. bearer. M12 min. drop rod.</p> <p>Incorporate additional drop rod mid-width through duct and bearer*.</p> <p>Weld (or fasten with with nuts and large washers) M15 min. strengthening rod. at mid-width of each flanged joint and penetration point to maintain cross section.</p> <p>Seal all holes with mastic.</p> <p>Above 4000mm × 4000mm: 50 × 50 × 6mm bearer. M12 min. drop rod.</p> <p>Incorporate additional drop rods through duct and bearer to ensure 1500mm max. spacing along bearer*. Weld (or fasten with nuts and large washers) M15 min. strengthening rod at each flanged joint and penetration point to ensure 1500mm max. spacing along joint. Seal all holes with mastic.</p> <p>*Additional drop rods to pass through duct and bearer. Rods to support bearer.</p> <p>*Top' of duct to be held in position with steel nuts and large steel washers.</p>		
3b	Mitre-joint fixing methods			
	½ hr HVAC & Smoke extract	1500mm × 1500mm		If duct dimensions exceed those shown, use welded steel pins as per Fire Duct system manual (see item 3a.)
	½ hr Kitchen extract	1500mm × 1500mm		
	1 hr HVAC & Smoke extract	1500mm × 1500mm		
	1 hr Kitchen extract	1500mm × 1500mm		
	1½ hr HVAC & Smoke extract	1200mm × 1200mm		
	2 hr HVAC & Smoke extract	1000mm × 1000mm		
4	Flanged cross joint	Type J3, J4, J5 or J6 to HVCA specification DW/142.		Strengthen joints (contact Rockwool)
5	Joint seal	May be included or omitted.		
6	Constructional fixings	Steel		
7	Bearers	30 × 30 × 3mm (min.) steel angle. See item 3a for ducts larger than 1500mm.		
8	Drop rods	M10 (min.) mild steel. See item 3a for ducts larger than 2000mm.		
9	Drop rod anchors			
	Fixed through steel suspension frame	Steel frame to be independently fire rated.		Fire protect steelwork.
	Fixed into concrete	Anchors to have confirmed fire rating.		If fire rating is unconfirmed and anchor is all-steel, ie without plastic or chemical components; affix 300mm × 300mm collar of unfaced Fire Duct Slab to soffit with FirePro Glue, keeping anchor central. Collar thickness to equal duct encasement layer. Optional self-tapping screws may be used to support collar. Glue adjacent Fire Duct drop rod protection to collar.
10	Spacing of suspension system			
10a	Horizontal ducts	1500mm max centres.		
10b	Vertical ducts: 2 or 3 sided protection	1500mm max centres.		Install additional supports
10c	Vertical ducts: 4 sided protection	Support at every floor (4 m max centres)		
11	Stiffening of duct at penetration detail	Duct flange or 30 × 30 × 3mm steel angle frame fixed with steel fixings at 300mm max. centres. To be positioned within the width of the penetration. See item 3a for ducts larger than 3000mm.		Install steel angle frame.
12	Compartment wall	Fire rated masonry, concrete, brick, block, plasterboard or other fire rated construction.		

## Typical specification clauses for rectangular ducts to be read in conjunction with System options on pages 2-3

### Welded pin fixing method

- 1 All ductwork is to be insulated with .....\* mm Rockwool Fire Duct Slab, having a factory applied reinforced aluminium foil to one face and complying with Building Regulations Class 'O' requirements.
- 2 The Fire Duct Slab is to be affixed to the duct using 2.5mm diameter welded steel pins and 38mm spring steel washers in accordance with the Rockwool manual 'Fire Duct systems'.
- 3 The foil facing is to be removed from any surfaces to which FirePro Glue is to be applied.
- 4 All corner joints are to be fixed with pigtail screws at 250mm maximum centres. Screw length is to be 2 × slab thickness.
- 5 All cross joints are to be filled with FirePro Glue and held tightly closed.
- 6 Drop rods and bearers are to be at 1500mm maximum centres and to be M10 steel rod and 30 × 30 × 3mm steel angle respectively. Ductwork is to be generally in accordance with HVCA Specification DW/144.
- 7 Drop rods and exposed bearers are to be insulated with ..... mm Fire Duct Slab or .....† × .....\* mm Fire Duct Section, as appropriate. Rebates or cover pieces are to be used at duct flange and bearer locations according to site conditions and subject to Rockwool approval.
- 8 Where a vapour barrier is required, all exposed Fire Duct edges and penetrations through the foil should be sealed using soft self-adhesive aluminium foil tape.

### Alternative longitudinal joints

Delete clauses 3 and 5 in Method 1 above, and insert new clause 5:

- 5 All joints are to be filled with FirePro Glue and held tightly closed. Use nails at 500mm centres at corner joints to aid this process.

### Alternative cross joints

Delete clauses 3 and 5 in Method 1 above, and insert new clause 5:

- 5 All cross joints are to be covered with centrally positioned 100mm wide strips of Fire Duct Slab of the same thickness as the insulation. The cover strips are to be fixed along both edges using pigtail screws at 250mm max. centres.

\* Insert Fire Duct Slab insulation thickness required.

† Insert appropriate overall diameter.

### Mitre-joint fixing method

- 1 All ductwork is to be insulated with .....\* mm Rockwool Fire Duct Slab, having a factory applied reinforced aluminium foil to one face and complying with Building Regulations Class 'O' requirements.
- 2 The Fire Duct joints at ductwork corners are to be 45° mitred. Square butt joints to be used elsewhere.
- 3 The foil facing is to be removed from any surfaces to which FirePro Glue is to be applied.
- 4 All joints are to be filled with FirePro Glue and held tightly closed.
- 5 All mitred joints are to be held tightly closed with nails (length = approx. 2 × Fire Duct Slab thickness) until the glue has fully cured. 2 nails juxtaposed at 90° are to be located at 3 points per 1200mm length of mitred joint and at 5 points per 2000mm length.

- 6 Drop rods and bearers are to be at 1500mm maximum centres and to be M10 steel rod and 30 × 30 × 3mm steel angle respectively. Ductwork is to be generally in accordance with HVCA Specification DW/144.
- 7 All drop rods and exposed bearers are to be insulated with .....\* mm Fire Duct Slab or .....† × .....\* mm Fire Duct Section, as appropriate. Rebates or cover pieces are to be used at duct flange and bearer locations according to site conditions and subject to Rockwool approval.
- 8 Where a vapour barrier is required, all exposed Fire Duct edges and penetrations through the foil should be sealed using soft self-adhesive aluminium foil tape.

### Sitework

#### Handling

The Fire Duct range of products is light, easy to handle and simple to fix. The products can be cut and shaped using knives, saws, etc.

### Health and safety

Current HSE 'CHIP' Regulations and EU directive 97/69/EC confirm the safety of Rockwool mineral wool; Rockwool fibres are not classified as a possible human carcinogen.

The maximum exposure limit for mineral wool is 5mg/m<sup>3</sup>, 8 hour time-weighted average.

A Material Safety Data Sheet is available from the Rockwool Marketing Services Department to assist in the preparation of risk assessments, as required by the Control of Substances Hazardous to Health Regulations (COSHH).

### Environment

Rockwool insulation relies on entrapped air for its thermal properties; air is not a VOC and it does not have Global Warming Potential (GWP) or Ozone Depleting Potential (ODP).



### More information



For further details visit our website at [www.rockwool-firepro.co.uk](http://www.rockwool-firepro.co.uk)

**ROCKWOOL**  
F I R E S A F E I N S U L A T I O N

Rockwool Limited Pencoed, Bridgend. CF35 6NY  
Email: [info@rockwool.co.uk](mailto:info@rockwool.co.uk) Web: [www.rockwool-firepro.co.uk](http://www.rockwool-firepro.co.uk)

Rockwool Limited reserves the right to alter or amend the specification of products without notice as our policy is one of constant improvement.

The information contained in this data sheet is believed to be correct at the date of publication. Whilst Rockwool will endeavour to keep its publications up to date, readers will appreciate that between publications there may be pertinent changes in the law, or other developments affecting the accuracy of the information contained in this data sheet.

The above applications do not necessarily represent an exhaustive list of applications for Fire Duct systems. Rockwool Limited does not accept responsibility for the consequences of using Fire Duct systems in applications different from those described above. Expert advice should be sought where such different applications are contemplated, or where the extent of any listed application is in doubt.